

Drago 150 180 200

IC counterbalanced trucks,
Diesel and LPG, from 1500 to 2000 Kg

Ergonomic, quiet, easy to manoeuvre

Hydraulically controlled
hydrostatic transmission

The CESAB DRAGO 150 180 200 has a short overall length and has been designed for general purpose handling duties in confined spaces. The range comprises models with lifting capacity from 1500 to 2000 Kg and lifting height up to 7000 mm.

With its low centre of gravity, the very stable design utilises two independent high power front wheel hydraulic motors driven by a hydrostatic pump coupled to the engine. This design gives higher acceleration and braking performance characteristics, yet delivers lower levels of fuel consumption – especially when frequent changes of direction are made.

2.5 litre diesel or 2.2 litre LPG low emission engines are standard. Two braking systems: hydrostatic deceleration and oil bath brakes.

A diesel version with in direct injection and a LPG version for combined internal/external applications assure high versatility. The engine ensure quiet operation, low emission levels and ease of maintenance.

The hydraulic power steering unit is installed underneath the platform, giving simpler connections and quieter operation. The pedals are mounted on the dashboard for easy adjustment and quicker maintenance.

Clearview mast with high torsional rigidity to allow safe handling of loads of all sizes.

The front wheels – which are among the largest in this class of trucks – give load stability, operator's comfort and easy manoeuvring on uneven ground.

High efficiency and low operating costs. Increased maintenance and inspection interval have significant benefits in terms of costs and machine down-times.



The new complete cab, available as an option, is installed inside the profile of the overhead guard. It is equipped, as standard, with high-quality panelling, accessories and soundproofing, lexan roof complete with gutters, sliding windows on both doors and pantograph windscreen-wipers.



The drive position, easily accessed thanks to the wide step, provides an excellent view, a full suspension seat and a steering column that adapt readily to all driver styles. The new steering column is inclined towards the operator and easily adjustable for increased driving comfort.



The automobile-style dashboard has main function indicator lights plus warning signals for operating status and major components wear.



High performance, low fuel consumption and noise level are the main advantages of the new TOYOTA engines. The engine components are easily accessible thanks to the new internal layout, allowing simpler, quicker servicing.

At Your Local Dealer

CESAB S.p.A. products, specifications and technical data are subject to change without notice.

Options

- Automatic engine acceleration on lifting (standard on LPG).
- Complete cab, with or without heating.
- Working lights.
- Dusty environment version.
- Catalytic exhaust.
- Twin wheels.

Cesab Ltd:

Unit 10, Regent Park, Booth Drive, Park Farm South, Wellingborough,
Northamptonshire, NN8 6GR
Tel. +44 1 933 670 460 - Fax +44 1 933 679 854
e-mail: sales@cesab.net

Cesab Carrelli Elevatori Spa

Via Persicetana Vecchia, 10 - 40132 Bologna (Italy)
Tel. +39 051 20.54.11 - Fax +39 051 72.80.07
website: www.cesab-forklifts.com - e-mail: cesab@cesab.it



11/08 - 0342088 - btaabv.com
gra_arch_0186

VDI 2198

		CESAB		CESAB		CESAB			
Characteristics	1.1	Manufacturer		CESAB		CESAB			
	1.2	Model designation		DRAGO 150		DRAGO 180			
	1.3	Power unit: electric (battery), diesel, petrol, LPG		diesel / LPG		diesel / LPG			
	1.4	Operation: manual, pedestrian, stand-on, driver seated		driver seated		driver seated			
	1.5	Load capacity	Q (kg)	1500		1800		2000	
1.6	Load centre	c (mm)	500		500		500		
1.8	Axle centre to fork face	x (mm)	390	(a)	390	(a)	390	(a)	
1.9	Wheel-base	y (mm)	1490		1490		1490		
Weights	2.1	Weight	kg	2870		2970		3070	
	2.2	Axle load with load, front/rear	kg	3700 / 670		4210 / 560		4570 / 500	
	2.3	Axle load without load, front/rear	kg	1300 / 1570		1330 / 1640		1360 / 1710	
Wheels and chassis	3.1	Tyres: C=Cushion, SE=Superelastic, PN=Pneumatic, TW=Twin		SE - PN - SE.TW (b)		SE - PN - SE.TW (b)		SE - PN - SE.TW (b)	
	3.2	Tyre size, front		23x9-10 - 23x9-10 - 6.50-10 (c)(d)(e)		23x9-10 - 23x9-10 - 6.50-10 (c)(d)(e)		23x9-10 - 23x9-10 - 6.50-10 (c)(d)(e)	
	3.3	Tyre size, rear		18x7-8 - 18x7-8 - NO		18x7-8 - 18x7-8 - NO		18x7-8 - 18x7-8 - NO	
	3.5	Wheels, number front/rear (x = driven)		2x - 4x / 2		2x - 4x / 2		2x - 4x / 2	
	3.6	Track width, front	b10 (mm)	892 - 922 - 1061		892 - 922 - 1061		892 - 922 - 1061	
	3.7	Track width, rear	b11 (mm)	863		863		863	
	3.7	Track width, rear	b11 (mm)	863		863		863	
Dimensions	4.1	Mast tilt, forward/backward	α / β (degrees)	5° / 10°		5° / 10°		5° / 10°	
	4.2	Height of mast, lowered	h1 (mm)	2160		2160		2160	
	4.3	Free lift	h2 (mm)	80		80		80	
	4.4	Lift height	h3 (mm)	3170		3170		3170	
	4.5	Height of mast, extended	h4 (mm)	3720		3720		3720	
	4.7	Height of overhead guard	h6 (mm)	2120		2120		2120	
	4.8	Height of driver's seat	h7 (mm)	1040		1040		1040	
	4.12	Towing coupling height	h10 (mm)	330		330		330	
	4.19	Overall length	l1 (mm)	3275	(a)	3275	(a)	3275	(a)
	4.20	Length to fork face	l2 (mm)	2275	(a)	2275	(a)	2275	(a)
	4.21	Overall width	b1/b2 (mm)	1098 - 1162 / 1446 (c)(d)(e)		1098 - 1162 / 1446 (c)(d)(e)		1098 - 1162 / 1446 (c)(d)(e)	
	4.22	Fork dimensions	s/e/l (mm)	35 x 100 x 1000		35 x 120 x 1000		35 x 120 x 1000	
	4.23	Fork carriage to DIN 15173, class/form A, B		II A		II A		II A	
	4.24	Width of fork carriage	b3 (mm)	900		900		900	
	4.31	Floor clearance, mast (with load)	m1 (mm)	89		89		89	
	4.32	Floor clearance, centre of wheel-base (with load)	m2 (mm)	125		125		125	
4.33	Aisle width with pallets 1000 x 1200 across forks	Ast (mm)	3659	(a)	3659	(a)	3659	(a)	
4.34	Aisle width with pallets 800 x 1200 along forks	Ast (mm)	3859	(a)	3859	(a)	3859	(a)	
4.35	Turning radius	Wa (mm)	2069		2069		2069		
4.36	Minimum distance between the centres of rotation	b13 (mm)	583		583		583		
Performance	5.1	Travel speed, with/without load	km/h	17 / 18		17 / 18		17 / 18	
	5.2	Lifting speed, with/without load	m/s	0.50 / 0.55		0.50 / 0.55		0.50 / 0.55	
	5.3	Lowering speed, with/without load	m/s	< 0.55		< 0.55		< 0.55	
	5.5	Tractive force, with/without load	N	9500 / 9500		9500 / 9500		9500 / 9500	
	5.7	Climbing ability, with/without load	%	19 / 27		17 / 27		16 / 27	
	5.9	Acceleration time, with/without load	s	-		-		-	
	5.10	Service brake: mechanical/hydraulic/electric/pneumatic		hydrostatic		hydrostatic		hydrostatic	
Drive	7.1	Engine manufacturer / type		Toyota 1DZ-III / Toyota 4Y		Toyota 1DZ-III / Toyota 4Y		Toyota 1DZ-III / Toyota 4Y	
	7.2	Engine performance	kW	38 / 37		38 / 37		38 / 37	
	7.3	Rated speed	min ⁻¹	2400 / 2400		2400 / 2400		2400 / 2400	
	7.4	Number of cylinders/displacement	cm ³	4-2486 / 4-2237		4-2486 / 4-2237		4-2486 / 4-2237	
	7.5	Fuel consumption VDI-cycle	l/h; kg/h	-		-		-	
Others	8.1	Type of drive control		stepless hydrostatic		stepless hydrostatic		stepless hydrostatic	
	8.2	Working pressure for attachments	bar	180		180		180	
	8.3	Oil flow for attachments	l/min	-		-		-	
	8.4	Noise level at driver's ear	dB (A)	79.3 / 79		79.3 / 79		79.3 / 79	
	8.5	Towing coupling, design/type DIN		-		-		-	

(a) with sideshift = + 34 mm

(b) TW not available with triplex mast

(c) with triplex mast, only 6.50-10 tyres available

(d) truck width with Triplex mast, SE (6.50-10) 1105 mm, wheel base 934 mm

(e) truck width with Triplex mast, PN (6.50-10) 1155 mm, wheel base 964 mm

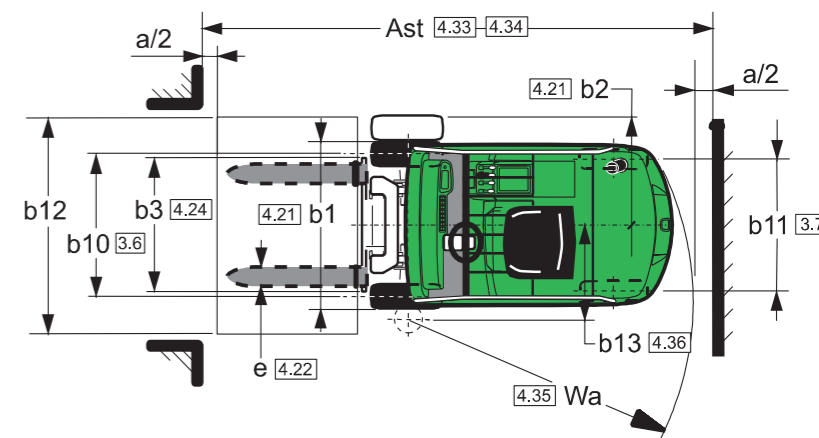
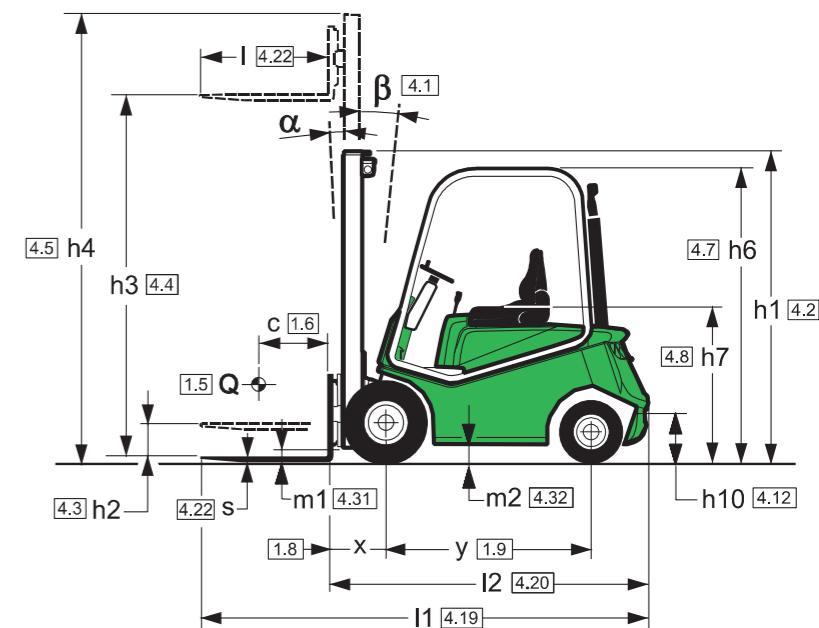

Masts specifications (1500 - 2000 Kg)

Mast	mm	Duplex					Duplex FFL			
h3	Lift height	2970	3170	3670	4170	4670	2840	3170	3670	4170
h1	Height of mast, lowered	2060	2160	2410	2660	2910	1990	2160	2410	2660
h2	Free lift	80	80	80	80	80	1410	1580	1830	2080
h4	Height of mast, extended	3520	3720	4220	4720	5220	3420	3750	4250	4750
α / β	Mast tilt forward/backward	5° / 10°					5° / 10°			

Masts specifications (1500 - 2000 Kg)

Mast	mm	Triplex					Triplex FFL						
h3	Lift height	4320	4965	5565	6165	6570	4320	4470	4970	5570	6170	6570	6970
h1	Height of mast, lowered	2010	2260	2460	2710	2860	2010	2060	2260	2460	2710	2860	3010
h2	Free lift	0	0	0	0	0	1430	1480	1680	1880	2130	2280	2430
h4	Height of mast, extended	4900	5570	6170	6820	7240	4900	5050	5550	6150	6750	7150	7550
α / β	Mast tilt forward/backward	5° / 8°					5° / 8°						